

# UWE Estates Design Specification

## Chapter 12: Controls & Metering



## Table of Contents

- 12.1 Change Control.....1
- 12.2 Building Management System (BMS) Engineering and Graphics.....2
- 12.3 Input/Output module (I/O) Architecture.....3
- 12.4 Automation Server Naming Convention .....3
- 12.5 Enterprise Server Folders.....3
- 12.6 Automation Server Folders.....8
- 12.7 Graphics..... 11
- 12.8 Software ..... 18
  - 12.8.1 General ..... 18
  - 12.8.2 Specific Requirements: ..... 19
  - 12.8.3 Trend and Extended Logging: ..... 20
  - 12.8.4 Support Tools: ..... 20
  - 12.8.5 Software Protocols: ..... 21
- 12.9 Metering..... 21
  - 12.9.1 Metering General ..... 21
  - 12.9.2 Mechanical metering ..... 22
  - 12.9.3 Electrical metering ..... 23
  - 12.9.4 Metering software..... 24
  - 12.9.5 Commissioning of Meters and Metering Systems..... 24

## 12.1 Change Control

Version Number	Date of Issue	Chapter Ref	Brief Description of Change(s)
P1	03/06/2016		G.M.Bodman issued for comment.
P2	21/03/2018		T.Arberry revised.
P3	29/07/2019		T.Arberry revised.
2021	Jan2021		No Updates. Revised to same format as all other Chapters and amended from Appendix 2 to Chapter 12.
2022	Jan2022	12.2	Introduction section enhanced
2023	Jan2023		Various updates throughout as detailed in 2023 version
2024	Feb2024		All Sections updated throughout. Guide renamed and Design Specification.

2025	JAN2025	NO CHANGES
2026	Feb2026	NO CHANGES

## 12.2 Building Management System (BMS) Engineering and Graphics

All buildings must have a similar look and feel to facilitate ease of use and efficient engineering. Refer to FR-X Block and/or FR-T Block for examples of the required standards as this applies to all elements throughout this document.

The UWE Building Management System comprises two platforms, Schneider ECOStruxure and Tridium Niagara. Schneider ECOStruxure forms the backbone for Frenchay and Bower Ashton, whereas Tridium Niagara interfaces with the Trend devices for Glenside, Arnolfini and Frenchay EP1, EP2 and ECC. All new controllers to be BACNet compatible.

BMS monitoring and control shall be provided to all significant items of Mechanical Plant items, unless agreed with the Estates Team.

UWE uses condition-based maintenance (CBM) regimes. This requires specific hardware and complementary control algorithms. This must be discussed at an early stage (RIBA stage 3) with the Estates BMS Manager to ensure all requirements are met at handover. Therefore, third party packaged units (e.g., AHUs) are not permitted unless the control strategies can be modified without additional software.

Provision must be made within the construction programme for client witnessing of the BMS controls prior to handover. A copy of all BMS graphics, control philosophy and bespoke software programming must be issued to the Estates BMS Manager for approval, with sufficient time period (two weeks) for comment.

All safety interlocks must be hardwired (i.e. temperature, pressure, airflow etc.) with indication only to be provided via the BMS where applicable.

All equipment MCCs must be linked to the site fire alarm system, with a provision to over-ride this link for regular fire alarm testing.

As a rule of thumb, room sensors should be located 1.5m AFFL, 0.5m from corners and vertical protrusions, away from draughts e.g. doorways, avoiding heat emissions and other thermal hot spots. They must be representative of the space being controlled.

Fridges/freezers that are considered business or research-critical must be monitored by the BMS.

All motorised dampers and valves should have their 'open' and 'closed' positions clearly marked on the side of their respective actuators and/or damper linkage prior to handover.

It is critical that all actuators, sensors etc. can be accessed from a position of safety (avoiding the need to work at height if practicable) and without the need for dismantling.

Trend and Extended Trend Logging shall be configured during the BMS commissioning stage, covering all plant provided under the contract, with the objective of providing a 'defect-free' installation at handover.

The Contractor shall include for the monitoring, analysis and defect rectification of all BMS components, and software engineering throughout the entire defect's liability period. The logged data shall be utilised during the Seasonal Commissioning phases.

Critical alarms shall be agreed at design and proven at handover. Email alerts shall also be configured. All AHU filters (Bag and Panel) shall be monitored utilising differential pressure transducers to determine clean dirty status. The data shall be incorporated into the CBM software.

To remove duplication of PIR devices the lighting systems shall be interfaced with the BMS to provide occupancy indication. This shall be via the lighting PIRs and local control switches. BACnet is the preferred interface – see Z Block for details.

### 12.3 Input/Output module (I/O) Architecture

I/O modules shall be in the same sequence on all projects subject to power supply limitations as follows: Power Supply Unit, Automated Server, Digital Output, Digital Input, Universal Input, Analogue Output.

Example:

Slot 1	Slot 2	Slot 3	Slot 4	Slot 5	Slot 6	Slot 7	Slot 8	Slot 9	Slot 10
PSU	AS	DO	DO	DI	DI	UI	UI	AO	AO

Note: All control panels shall no longer be supplied with hand/off/auto switches and indication lamps, therefore all output modules shall include override switches and the input LEDs configured to represent the status (e.g. on/off = green and fault = red). All modules shall have printed labels attached detailing the points being controlled/monitored.

### 12.4 Automation Server Naming Convention

Automation Server names shall reflect the building name, level, and room number to identify the location of the device and, since this is detailed in the alarm manager, to identify the source of alarms. For example:

BA – Bower Ashton

FC – Frenchay Campus (Historically FC and FR discriminate between HVAC and Security controllers in the same Continuum database so this convention shall be retained)

\_B\_ - B Block

\_D\_ - Block

BAP001 – Plant room reference

4D047 – Room Number

AS1 – Unique identifier for when multiple controllers are installed in the same location.

### 12.5 Enterprise Server Folders

Enterprise Server folders shall be created in the following format to allow easy navigation and review of buildings:

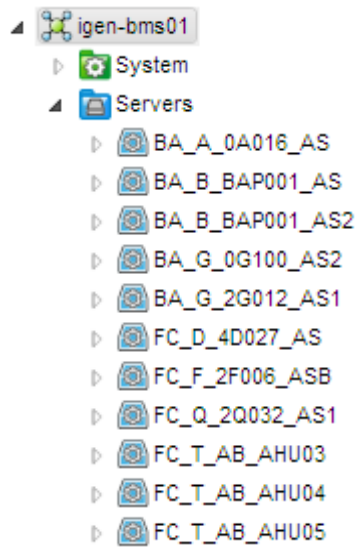

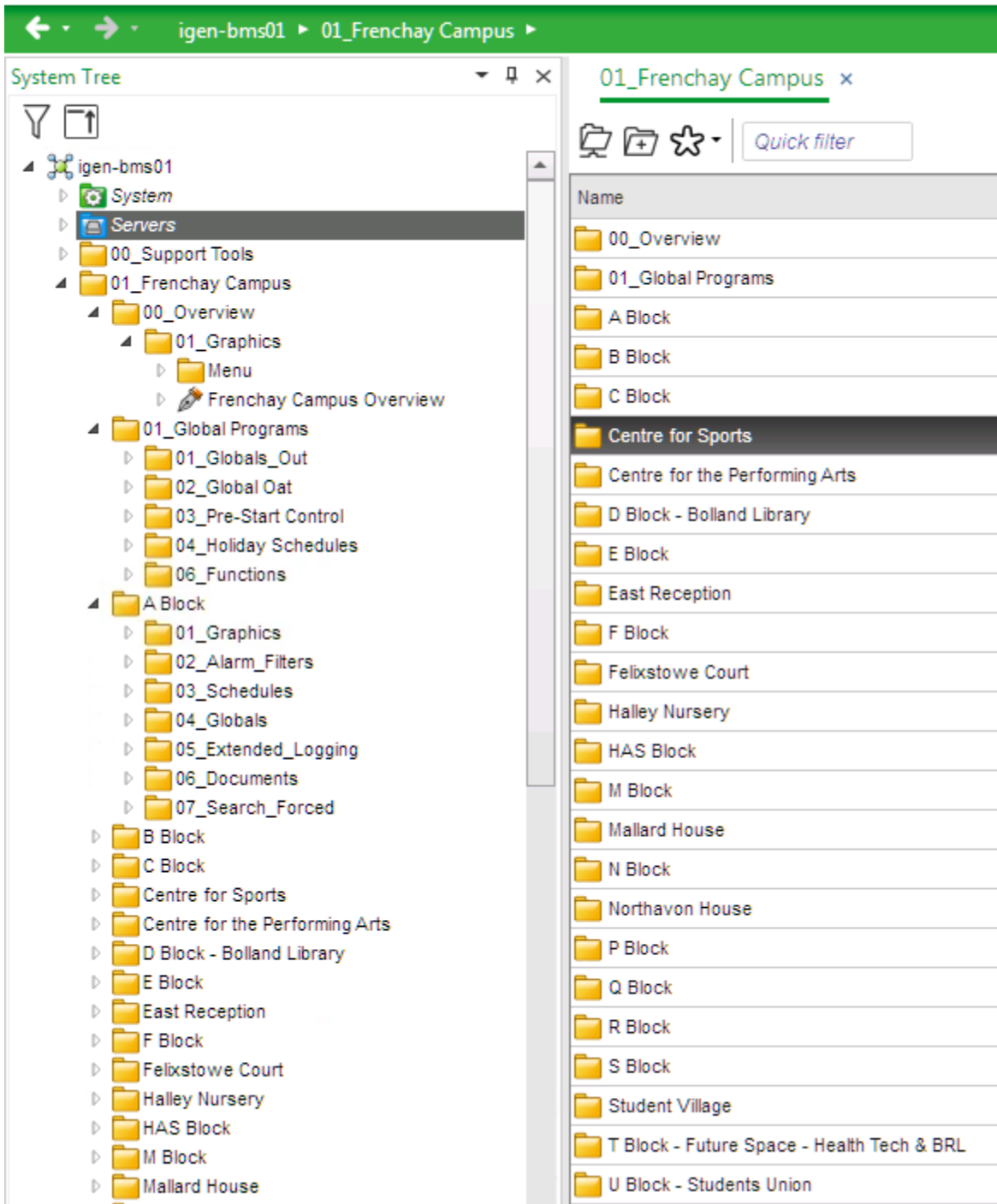

System: ES specific items, created by default

Servers: This folder contains the Automation Servers for each site and building

00\_Support Tools: This folder contains software and searches used for Daily BMS checks or Support Visits.

The subsequent folders shall then detail the campus (Frenchay, Bower Ashton etc.), blocks or areas being controlled and shall fall naturally in alphabetic order. Each folder contains a structure as shown and hold common points or shortcuts to items that are grouped for easy access or editing (e.g. Time schedules or Searches)

Example: Frenchay Campus

00\_Overview: Folder contains common graphic for site and the associated Menu software

01\_Global Programs: Includes Campus wide software that applies to all buildings.

04\_Holiday Schedules: As a minimum, two Calendar Exceptions shall be created under the Schedules folder. This allows each building to be overridden for extended holiday periods (e.g. Christmas and Easter) or open days. The exceptions shall be linked to all building schedules (except those that are 24/7 e.g. DHWS schedules) and allow the operator to control the building via one single point. Any additional common schedules shall be contained in this folder.

A Block: Any software or graphics relating to this building is included in this folder, however the associated server(s) remain in the Server directory and only shortcuts shall be added. Duplication of information is to be kept to a minimum.

04\_Globals: This folder identifies all points that are referencing or being referenced in different servers or buildings.

05\_Extended\_Logging: All extended logging shall be created within the ES and reference each server, where the trend logs are held.

06\_Documents: Contains documents relating to the building (e.g. Descriptions of Operation, panel drawings etc.) are stored.

07\_Search\_Forced: Any searches specific to this building shall be create here.

03\_Schedules: This folder shall store the schedules as detailed below

igen-bms01 ▶ 01\_Frenchay Campus ▶ X\_Block - Faculty Of Business and Law ▶ 03\_Schedules ▶ 01\_Holiday\_Schedules ▶

System Tree

- ▶ X\_Block - Faculty Of Business and Law
  - ▶ 01\_Graphics
  - ▶ 02\_Alarm\_Filters
  - ▶ 03\_Schedules
    - ▶ 01\_Holiday\_Schedules
      - ▶ Holiday\_Off
      - ▶ Open\_Day
      - ▶ Summer\_Winter
    - ▶ Heating Plant
    - ▶ Level 1
    - ▶ Level 2
    - ▶ Level 3
    - ▶ Level 4
    - ▶ Level 5
    - ▶ Level 6
    - ▶ Level 7
    - ▶ Vent Plant
      - ▶ AhuE1TimSch
      - ▶ AhuE2TimSch
      - ▶ AhuW1TimSch
      - ▶ AhuW2TimSch
      - ▶ AhuW3TimSch
      - ▶ AhuW4TimSch
      - ▶ KitExtTimSch
      - ▶ TeE1TimSch
      - ▶ TeE2TimSch
      - ▶ TeW1TimSch
  - ▶ 04\_Globals
  - ▶ 05\_Extended\_Logging
  - ▶ 06\_Documents
  - ▶ 07\_Search\_Forced
  - ▶ 08\_Common\_Points
- ▶ 02\_Emersons Green Campus
- ▶ 03\_Glenside Campus
- ▶ 04\_Bristol Business Park\_640
- ▶ 05\_Bower Aston

01\_Holiday\_Schedules x

Quick filter

Name	Description	Value
Holiday_Off	Holiday Off Schedule	False
Open_Day	Open_Day 07:00 - 19:00	False
Summer_Winter	Summer/Winter Heating Schedule	False

## 12.6 Automation Server Folders

The following Automation Server folder structure is included to allow easy navigation and review of plant within a building...

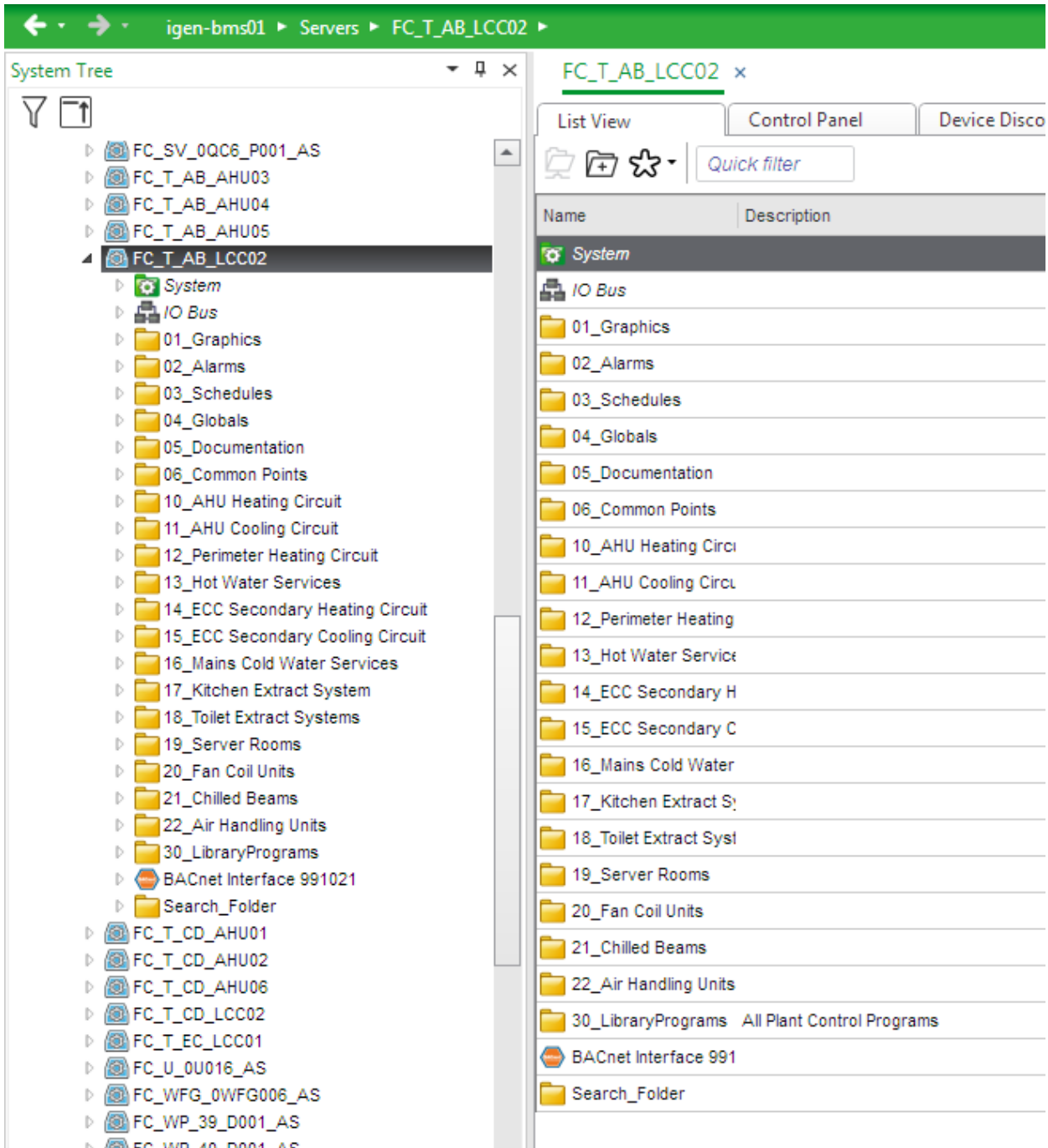

Subsequent folders and sub-folders shall be created to accommodate the plant controlled in a logical order. Examples:

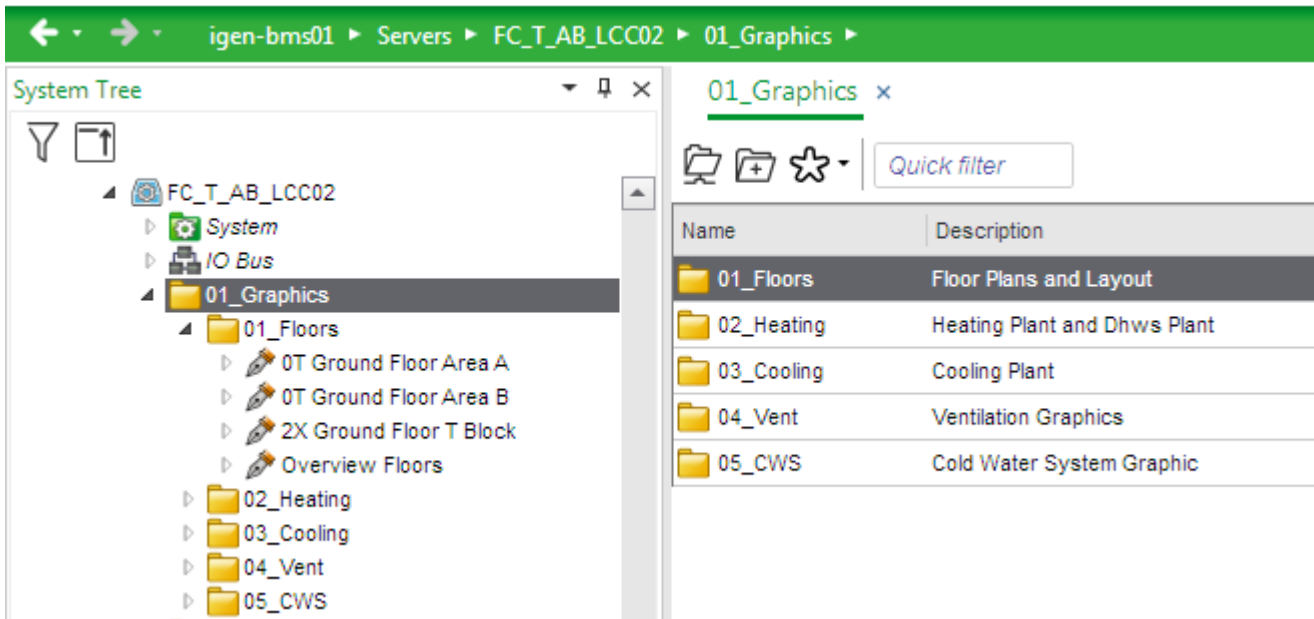
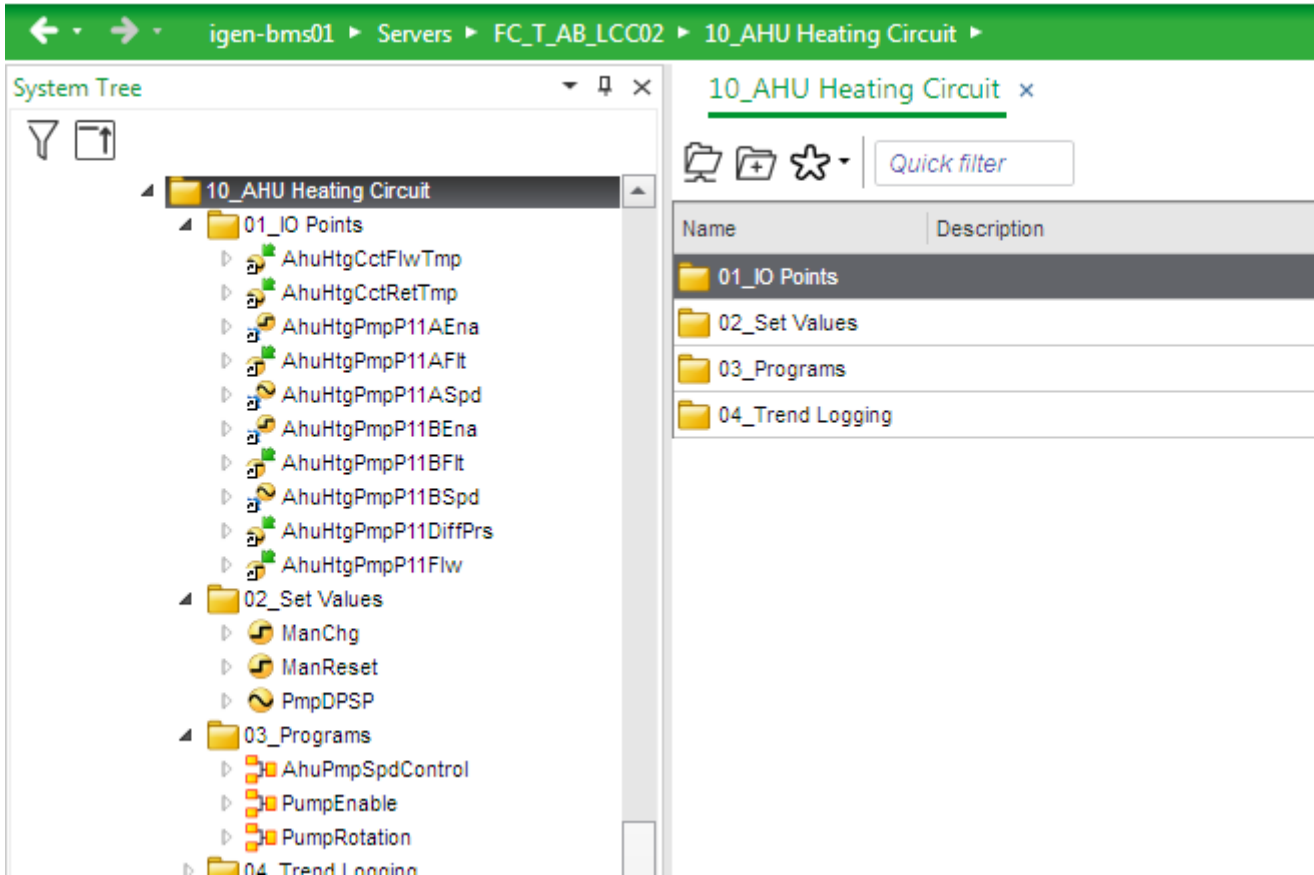

Where the AS Controller has Infinite devices (e.g. SCX920, TCX867) connected via its local comm port (A or B) then the controller nomenclature follows the same format as that for AS controllers. Although the name

should identify the controller's location the Location field shall also be completed to provide further information.

When BACNet devices are connected via the local comm port these can be either Schneider (including b3 devices), third part equipment (e.g. Monodraught Coolphase units, Nuaire Units) and Schneider's new range of sensors (to be implemented during the Z Block commissioning once updated to EcoStruxure software version 3.0)

The naming convention follows the system previously described (see following example).

IP BACNet protocol is the university's preferred method of connection to third party devices but Modbus can be provided in agreed circumstances. MSTP may also be accepted if all other methods have been exhausted.

LON protocol is not to be used.

Example:

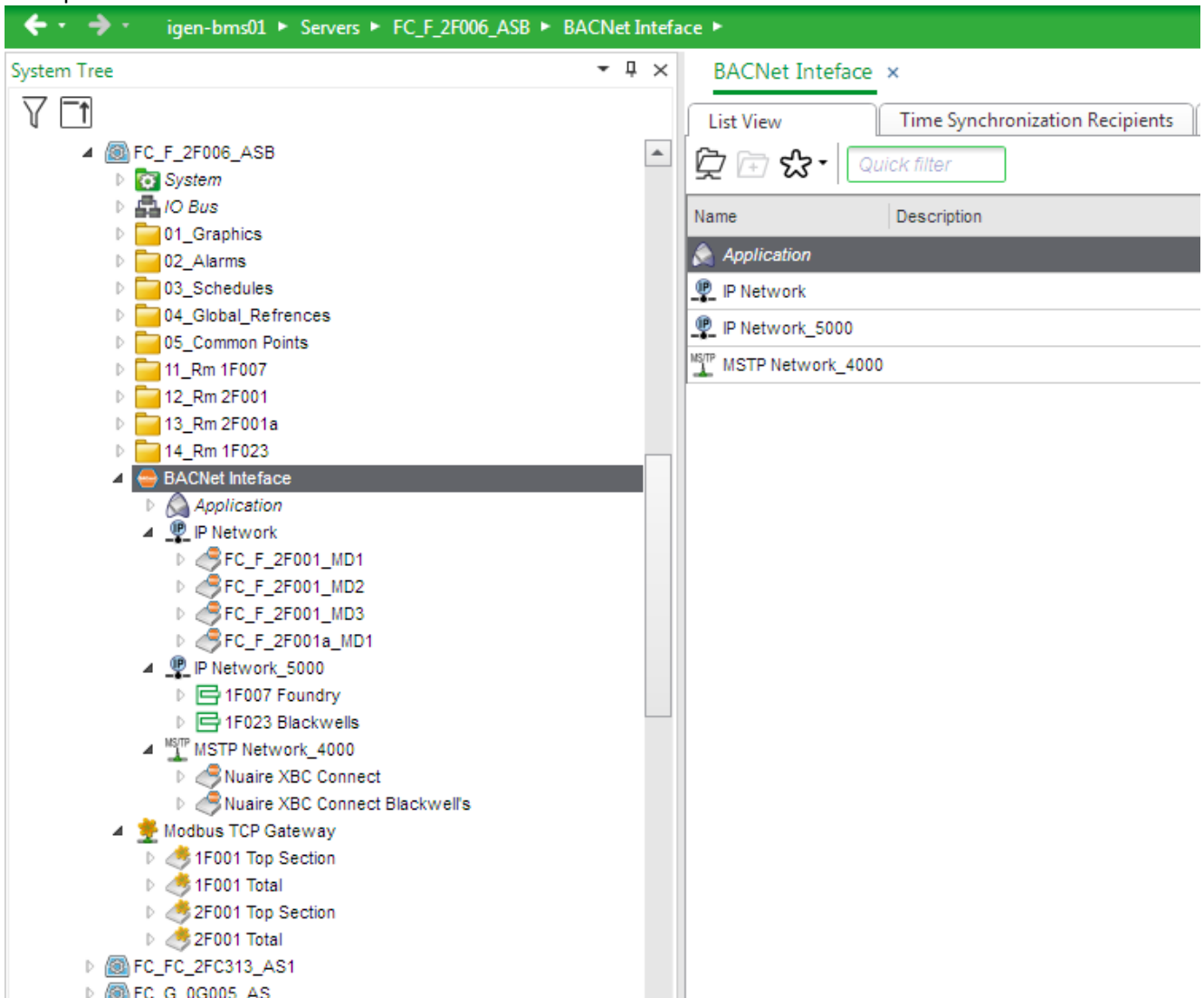

Where points from these controllers are attached to graphics (either Infinite and/or BACNet), then they shall have a duplicate point created in the Application folder, which is bound to the graphic and the controller point.

## 12.7 Graphics

It is the intention to navigate the system via the graphics package and therefore the user log-on shall load the site map by default. It can also be accessed via the shortcut at the bottom of the System Tree...

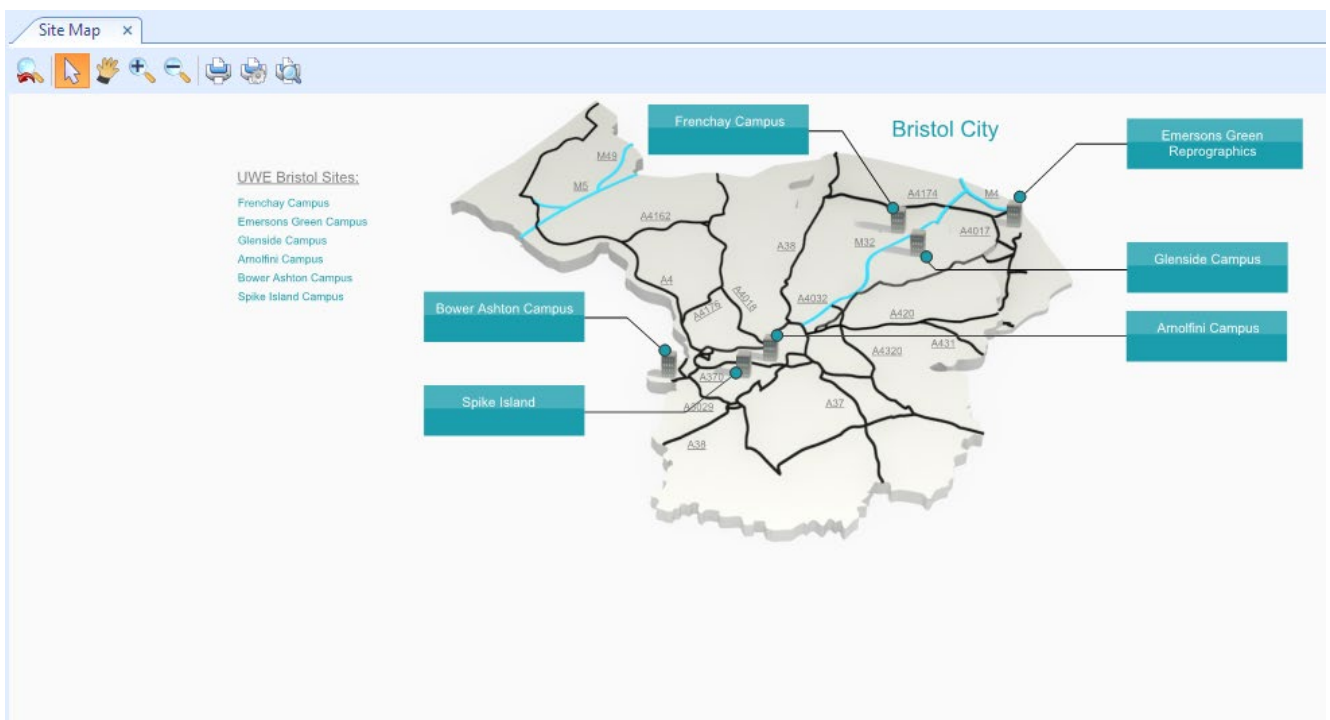
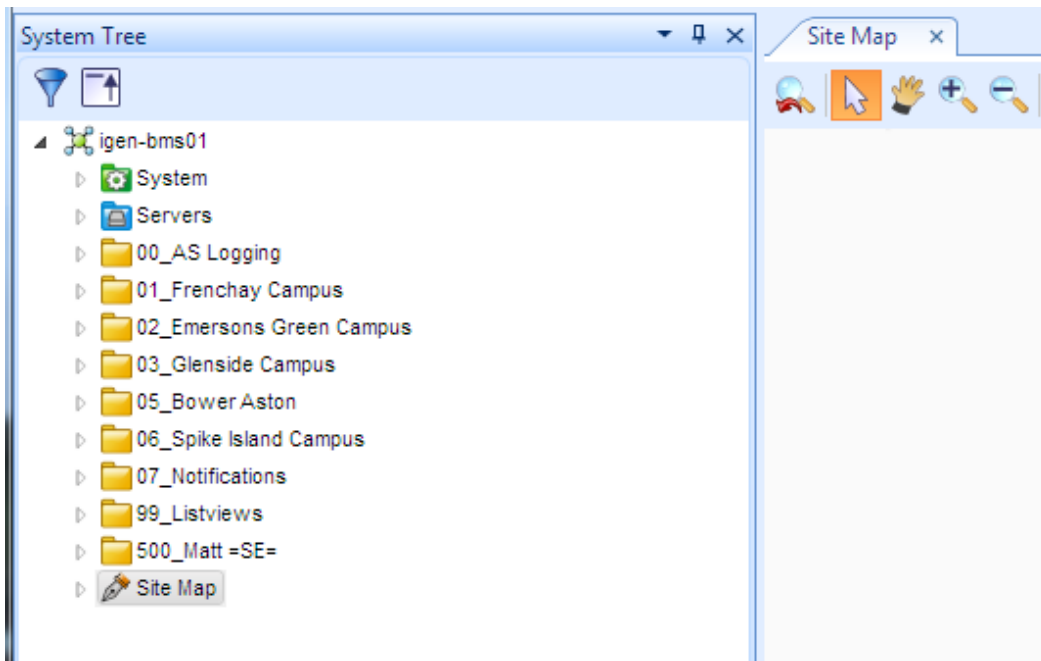

Each campus shall have an Overview image with links to the site's associated buildings, all links shall be present but only those with the relevant controllers shall be active.



Selecting the building or area shall generate a footprint image of the extent covered. E.g. FR-X Block:

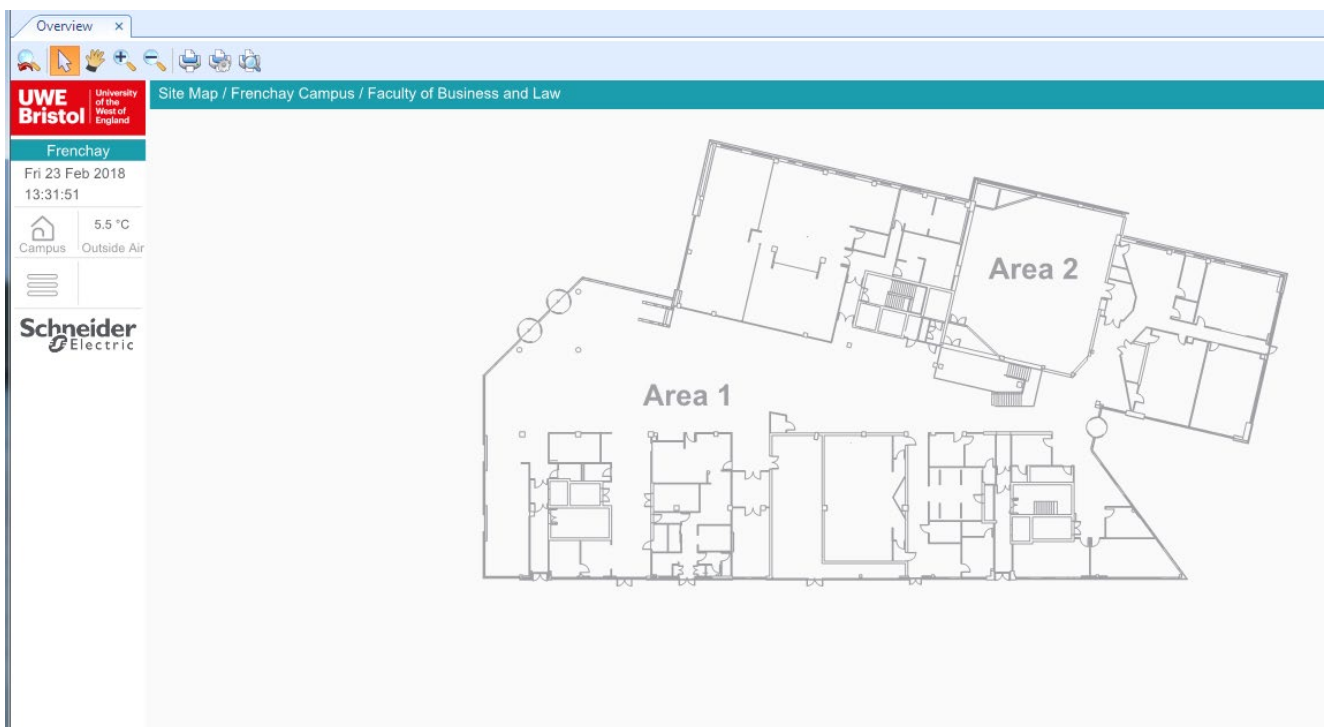

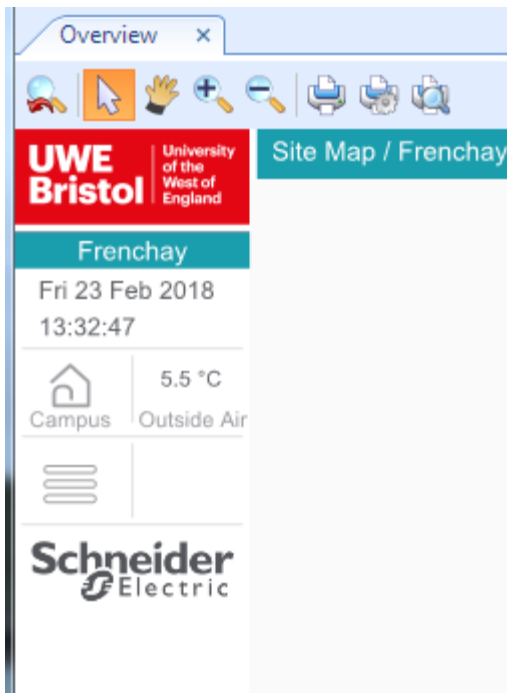

The “Campus” button returns the user back to the Building overview, then Campus and finally the original Site Map.

Three horizontal lines below the Campus button form a menu that allows the user to jump directly to the required plant - see the following image.

In addition, the user can use active areas or buttons on the main body graphic the user to jump to associated graphics

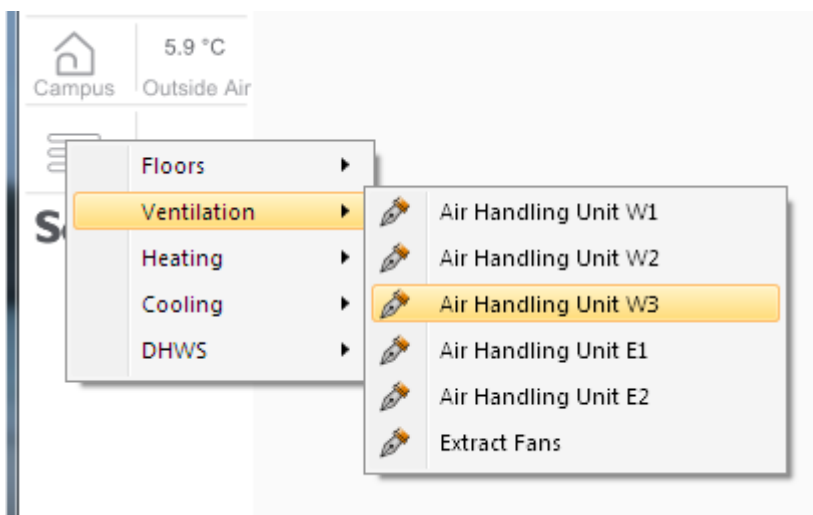

The Menu structure shall be configured via the ES structure of the system tree.

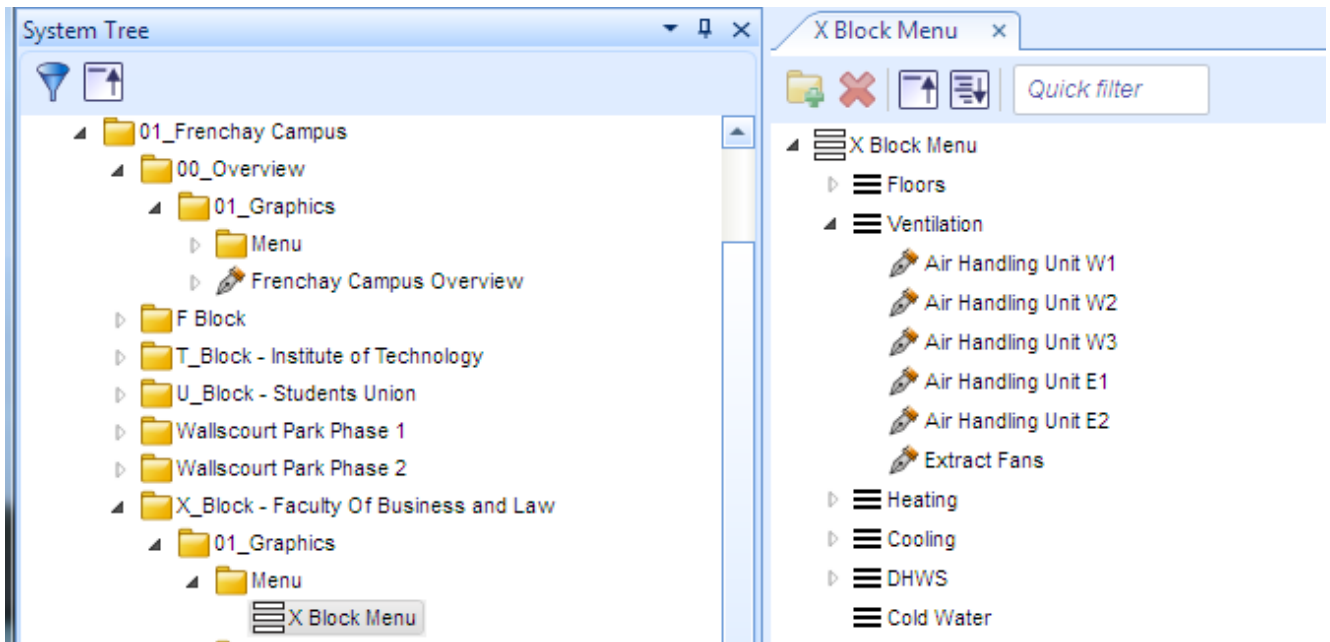

A title bar for each graphic shall also be active and allow the user to navigate to individual levels directly in a similar manner to the Campus button.

All floor levels shall be generated from CAD style drawings to show room numbers (UWE references **not** construction), sensor and controller locations and include links to plant rooms or relevant plant. The plans shall incorporate a switch to turn on/off the space temperatures (and CO<sub>2</sub> or Humidity if fitted) for the whole area.

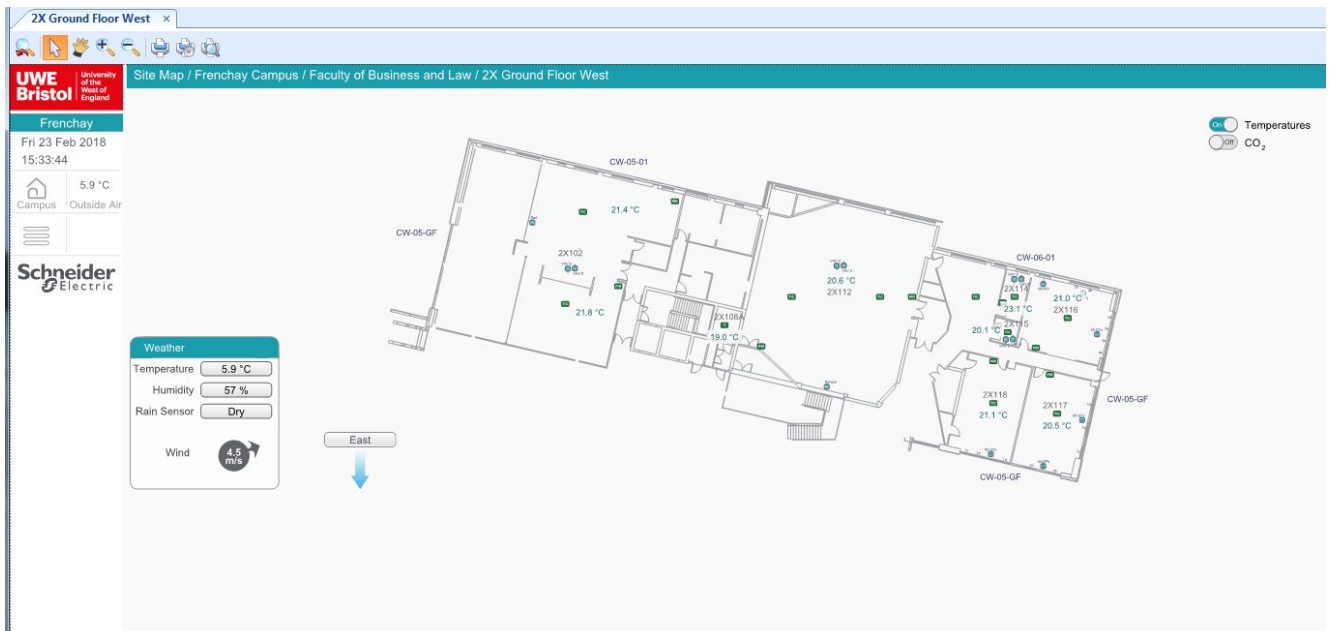

By selecting an individual room a pop out graphic displaying the room control detail and providing the operator access to override or change settings and time schedules. A “Reset Zoom” button returns to the original floor plan.

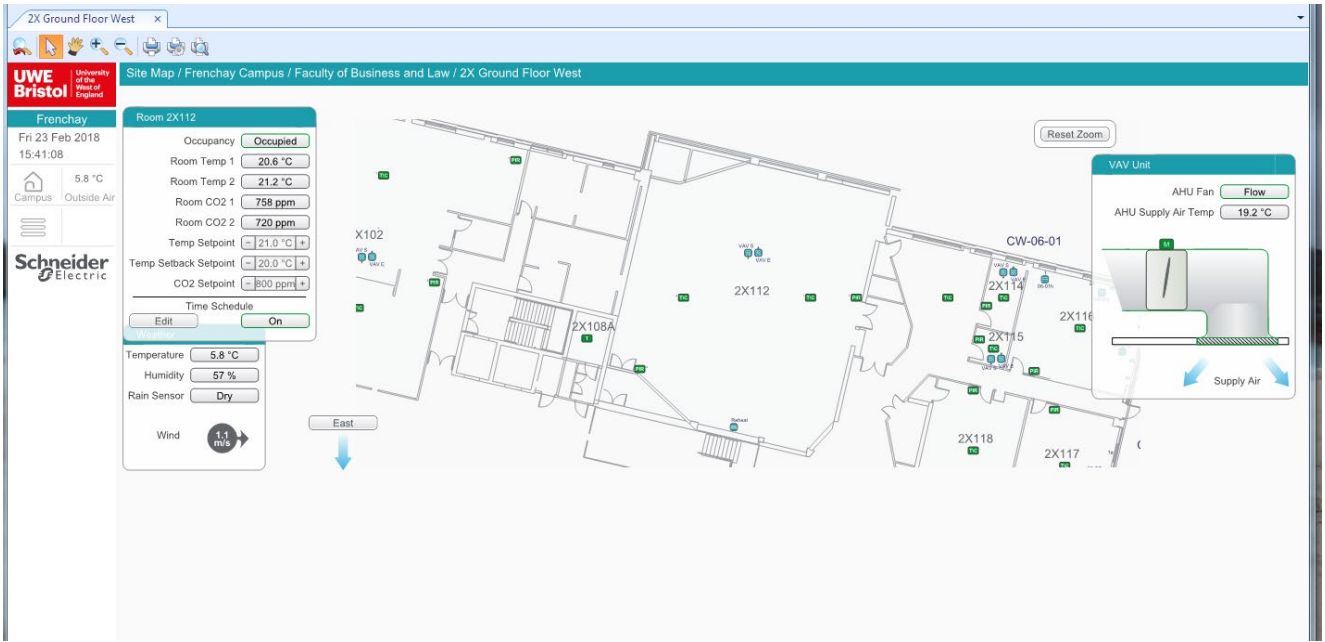

The following images are examples of acceptable plant graphics using agreed symbols:

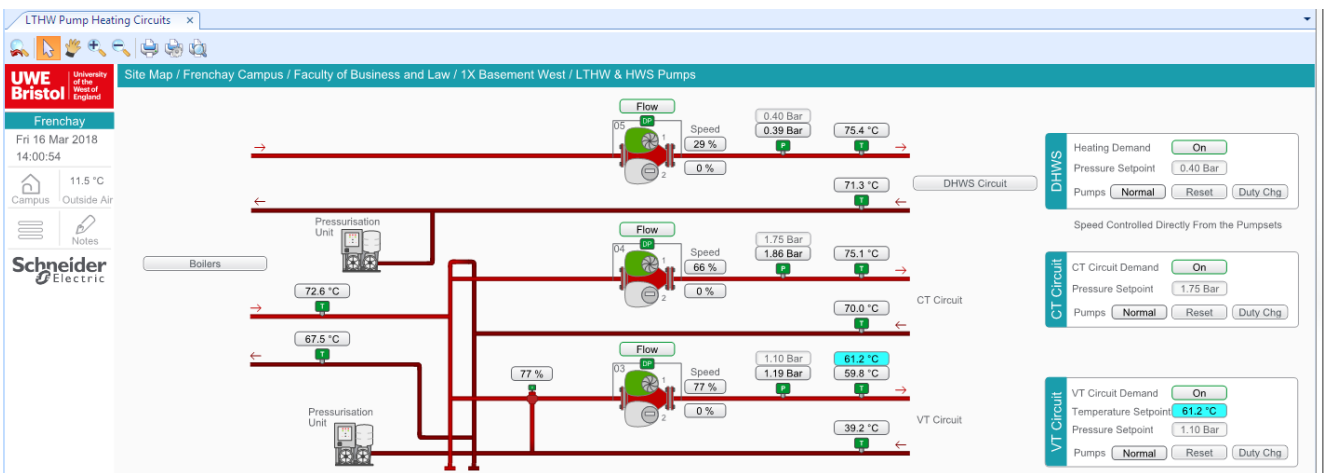
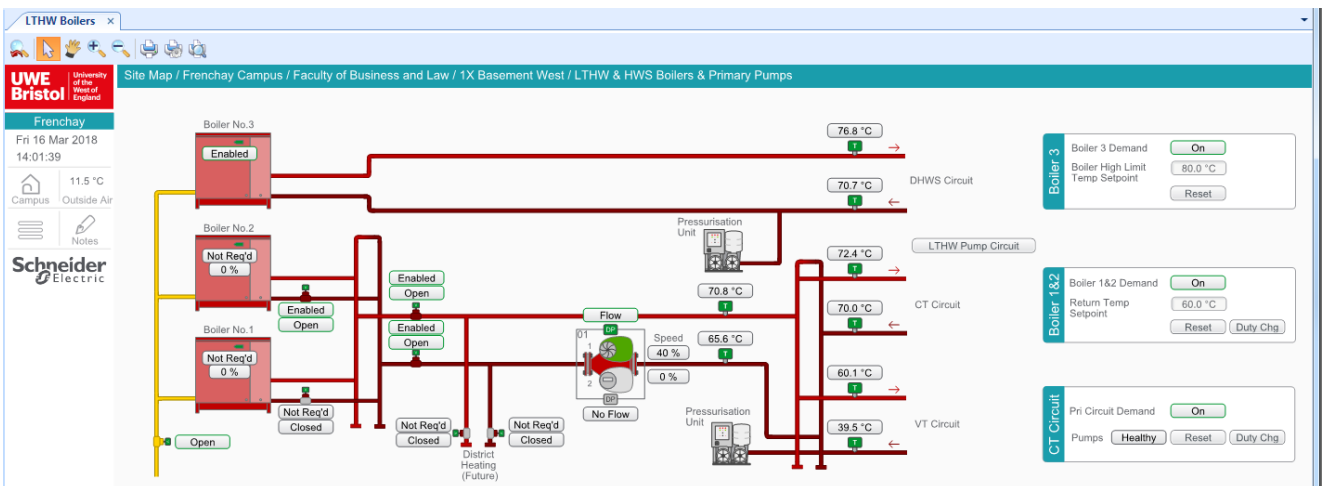

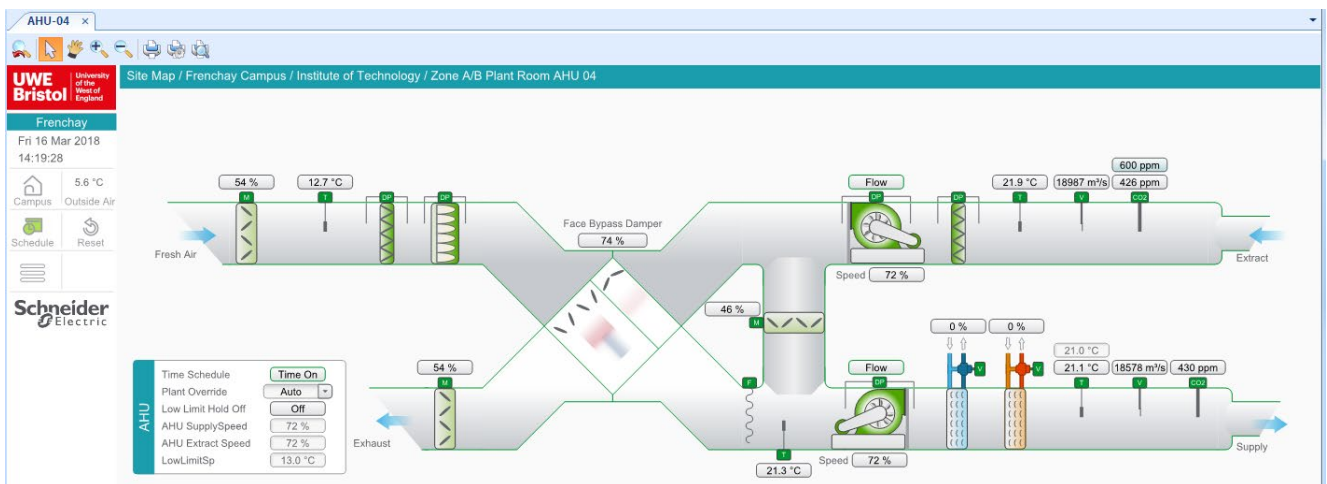
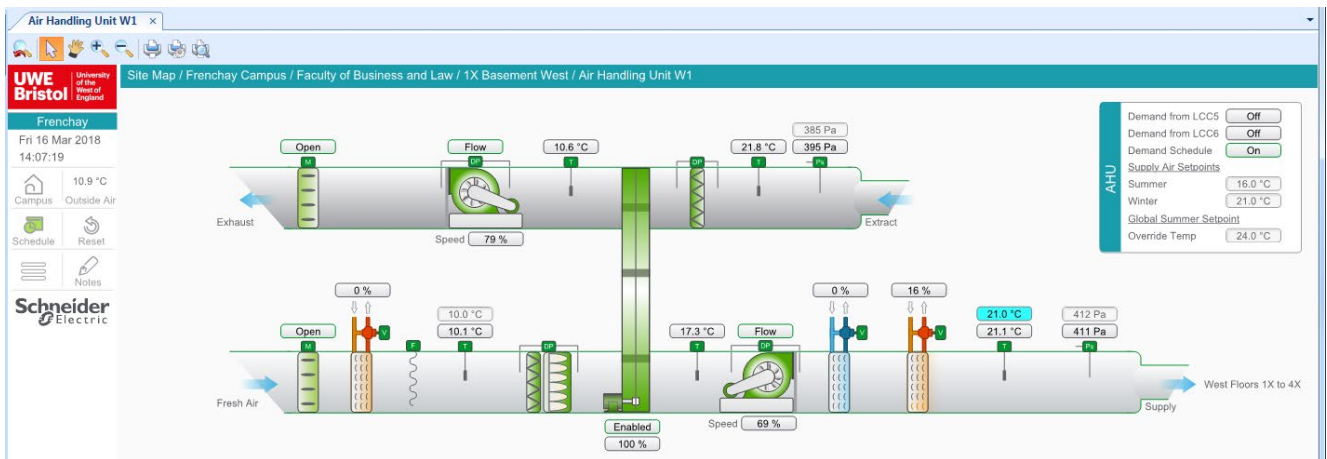
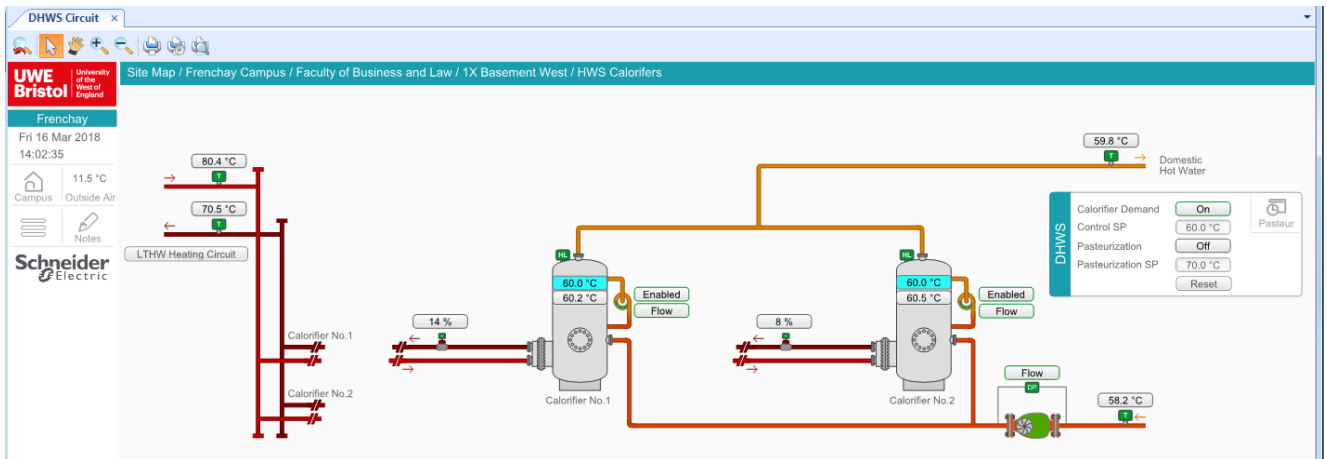

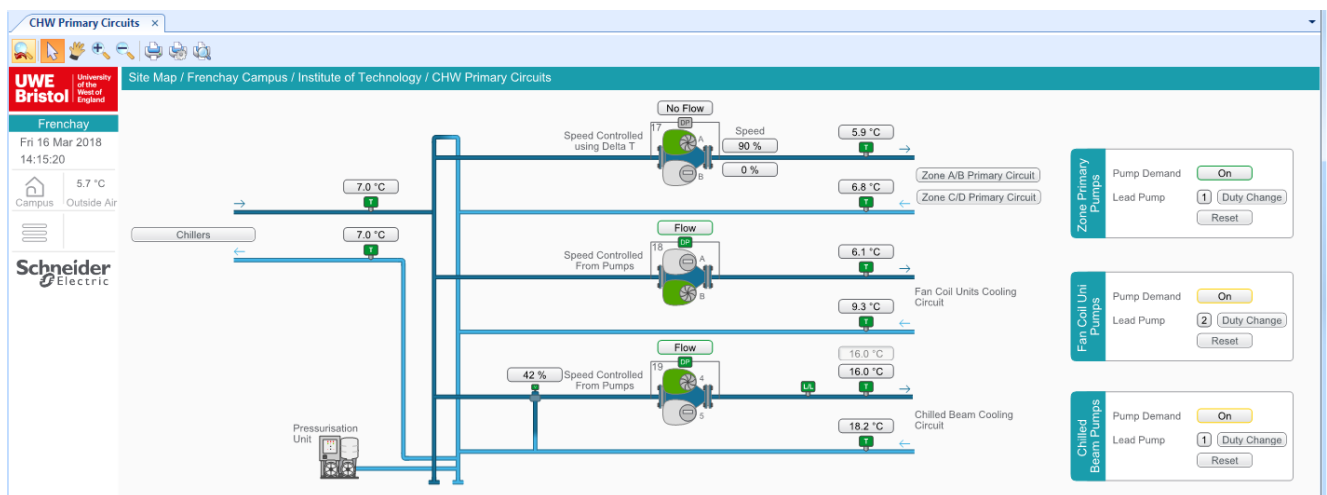
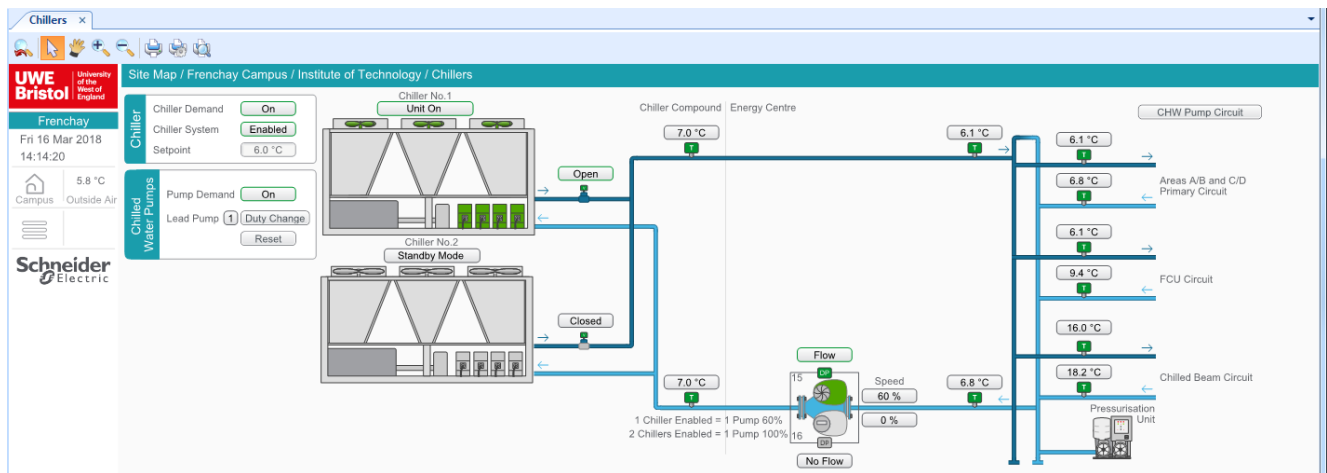
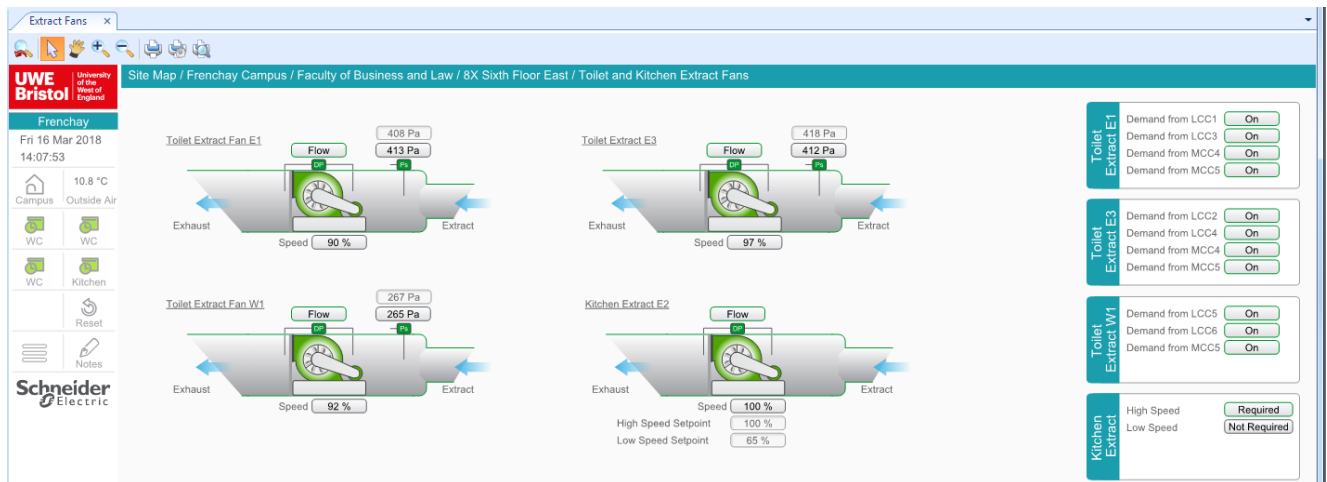

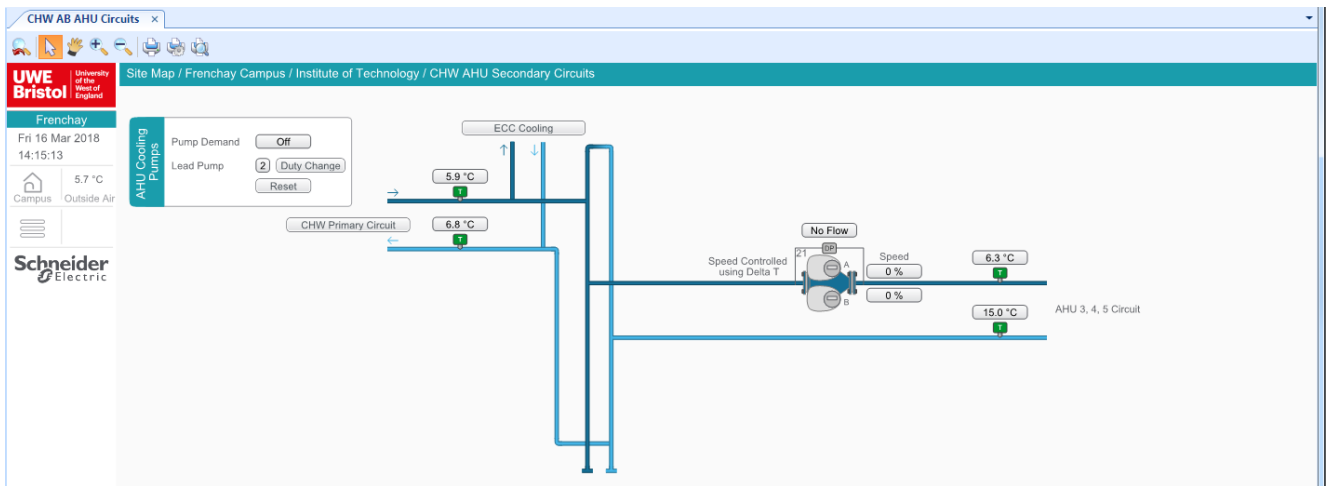

NO panels shall include Hand/Off/Auto switches or indication lamps (except panel power etc.) and therefore a graphic shall be produced to mimic how the panel fascia would have looked. The I/O module switches shall provide feedback to indicate the H/O/A status and the digital inputs shall provide condition status.

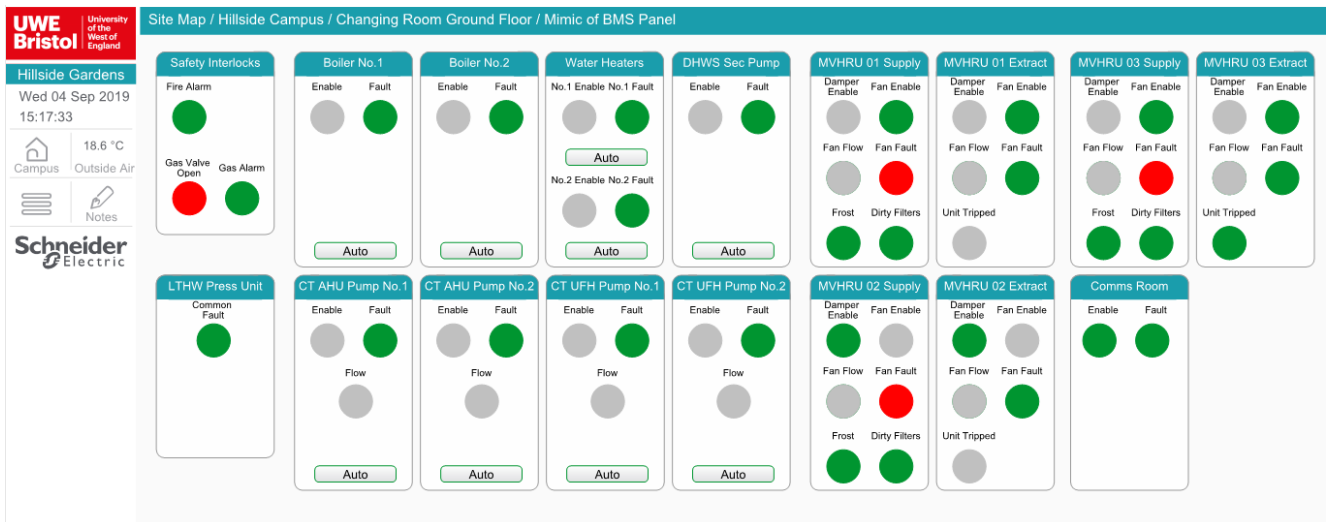

## 12.8 Software

### 12.8.1 General

The preferred programming method will use Function Block programs therefore most applications will be programmed this way. This does not preclude the use of Script programs; for instance, if a particular application could not be achieved in Function Block but can be by using Script. When software is being created in Infinet or b3 controllers then this remains as Script as a requirement of the product.

Plant demand shall be determined by the individual space requirements; therefore, each controllable space shall have a time schedule as a minimum. Where there are heating or cooling demands from coils etc. then a demand is generated only if a percentage (10% adjustable) is greater than 20% open. The demand is removed when all valves have been closed for period of 5 minutes.

Software developed for FR-X and FR-T Blocks shall be used as the basis of all control. There are numerous example Descriptions of Operation providing the details of the different elements, all available upon request. For example: Typical LTHW & Vent - Business & Law (FBL) X-Block Part 3 - M&E. Window Control & Natural Ventilation - FBL Perimeter & NV Control Strategy. Typical FCU & Chilled Beam - T Block & Energy Centre Controls Description.

**12.8.2 Specific Requirements:**

*12.8.2.1 IT Comms Rooms:*

AC Units shall operate 24/7 so do not require BMS enable signal. Unit fault and space temperature monitoring shall be included and the space temperature shall raise an alarm above 26°C. Members of the Estates and IT departments shall receive these alarms via email as determined by the current requirements.

*12.8.2.2 Alarms:*

In conjunction with the UWE requirements, alarms shall be created for all points as required. Alarms deemed critical form part of the escalation procedure, monitored via the Remote Bureau and added to the email circulation.

All alarm priorities shall comply with the following standard:

<b>Alarm Priority Allocation</b>	
Priority	Alarm type
<b>1-10</b>	
1	Safety Critical
2	Fire Alarms
4	Sprinkler Fault
5	Frost Condition
6	Gas Detection
7	Smoke Extract
8	<i>Spare</i>
9	Bureau Emailed Alarms
<b>11-20</b>	
11	Server Room Alarms
12	Cooling Unit Faults
13	Temperature High Alarms
14	Generator Faults
15	Trace Heating Fault
16	PHX Fault
<b>21-30</b>	
21	Plant Faults
22	HWS Low/High Temp Alarms
23	Pressurisation Unit Faults
24	Boiler Faults

25	Pump Faults
26	Both Pumps Failed
27	MVHR
28	HWS Plant
29	Chiller Faults
30	Lift Alarms
31-40	
32	High Temperature
33	Humidity
34	CO <sup>2</sup> Alarms
35	Filter Alarms
41-48	Sensor Faults – Out of Range
49-59	
49	Emailed Maintenance Alarms inc. CBM
60-95	
60	Window controls
61+	<i>Spare</i>
95-100	Miscellaneous
99	Rain Water Plant
100	100 - WCP Plant Alarms – HWS Boost etc.
> 101	System Alarms e.g., log sample missed

### 12.8.2.3 *Global Calendars:*

Global Calendars shall be linked to each Time Schedule to allow the Open\_Day and Holiday\_Off functions to operate for each Campus independently.

### 12.8.3 **Trend and Extended Logging:**

Comprehensive logging shall be configured suitable for use in the seasonal commissioning process and to confirm correct operation post-handover. This shall include extended logging so that the historic data can review a minimum of 365 days.

Trend logging shall be configured within the associated Automated Server and extended logging created and stored within the Enterprise Server structure.

### 12.8.4 **Support Tools:**

Support Tools are used by Estates staff to review the status of all plant on a daily basis and is accessed via the Site Map graphic. This review confirms the correct operation of heating, cooling and HWS plant and collates the data in simple to view tables. Any additional plant shall be included within these graphic pages.

### 12.8.5 Software Protocols:

All third party devices shall be restricted to use BACNet IP or Modbus IP only, under pre-agreed circumstances MSTP or hard-wired RS485 connections may be acceptable. LON is not a supported protocol.

## 12.9 Metering

### 12.9.1 Metering General

Metering is used extensively in UWE for the following purposes:

- Carbon reporting
- Charging users of space and equipment
- Energy monitoring
- Leak monitoring

No meters must be disabled, moved, replaced or removed without contacting the Carbon & Energy Team to discuss the implications of this. The same applies to any datalogging or communications equipment associated with the meters.

Metering is an essential component of projects, where spaces are being divided for separate or tenanted usage or where replacement or new heating or cooling systems are being installed or zoned. The expectation for all metering is as follows:

- Meter data shall be recorded at half hourly intervals
- All meters will be clearly labelled with serial number and with an easily read end use description that relates to the area or item being metered.
- Renewable energy generation will be sub-metered
- A thorough set of mechanical / electrical schematics will be provided showing the locations of all meters, clear details of areas monitored by each meter, as well as information on maintenance and use of meters.
- Meters should be easily accessible with the use of Facilities keysets, should be outside of student accommodation private areas / cleaning cupboards / etc. Meters should be positioned to facilitate ease of maintenance and manual (visual) meter reading without any access restrictions and (for mechanical meters) include isolation valves either side of the meter for safe removal.
- Accommodation should be metered according to flat or cluster.

All meters must be fully installed, commissioned and operational at handover, with meters identified by the Carbon and Energy Team to be added onto the university's eSight energy management software platform (see section 12.9.4 below).

### 12.9.2 Mechanical metering

Metering and sub metering of utilities shall be installed as per CIBSE guide TM39, Heat Network Regulations (2014), BREEAM requirements, and The Building Regulations 2000 Part L Conservation of Fuel and Power. For the sub-metering of mechanical systems (HVAC and Mains Water Services), the following principles should be followed:

- At least 90% of the estimated annual energy consumption for each fuel to be metered separately.
- Major plant that consumes more than 10% of the building energy should be sub metered.
- Sub metered per floor (particularly for water services).
- Sub metering any lettable spaces e.g. leased spaces to shops or businesses within UWE.
- Any cooling loads shall be metered separately.

Space heating, cooling and DHW generating plant shall be individually and separately metered for the fuel being used and the heat/coolth energy being generated.

Metering of electricity supplying mechanical plant shall be installed to all distribution boards either in the main switchboard or integrally in each distribution board.

Mechanical meters shall be appropriately sized to accurately measure the characteristics of the associated load throughout normal expected operating conditions. Connected loads must be understood to establish the lowest and highest flow conditions. The  $Q_{min}$  must be considered and properly calculated so that meters will not be oversized. Choice of meter must be best fit, not necessarily the cheapest option. Introduction of a meter must not affect the performance of the plant or equipment in any way.

Where heat metering is to be installed, all flow measurement elements must be of ultrasonic measurement type whereby the ultrasonic flow body is cut and permanently mounted into the pipe. Preferred Supplier to be Kamstrup but others may be considered in consultation with Estates Operations Team and Carbon & Energy Team. Temperature probes must be of the immersion pocket type and not be strapped on to the outside of pipework. Heat meters must display their energy values in kWh not MWh meters.

Standard mechanical hot water meters used as flow measurement within a heat meter arrangement are not acceptable as these are not designed for heating systems and can corrode.

Isolation valves must be fitted on both sides of the meter for ease of maintenance. Heat meters should be powered by mains not battery and should have Modbus communications protocol.

Water and gas meters shall be appropriately sized for the full expected range of flow measurement and can have pulse output communications. Isolation valves shall be installed both sides of meters.

All mechanical meters installed into pipework DN100 or larger shall have by-pass valve/pipework arrangements to allow removal of the meter without disruption to the site or building.

Where meters are to be used for tenant billing purposes, these should be approved by the Measuring Instrument Directive (MID) or certified under UK national legislation as required.

Where a building or development includes connection to grid or incoming utility supplies where billing utility fiscal meters are included, then these fiscal meters shall also be connected to the same UWE datalogging system.

Where the system needs to be augmented then a complete system shall be installed.

### 12.9.3 Electrical metering

Metering is an essential component of projects, where spaces are being divided for separate or tenanted usage or where replacement or new heating or cooling systems are being installed or zoned – in such instances it is expected that sub meters will be installed to record consumption. The expectation for all metering is as follows:

- Meter data shall be recorded at half hourly intervals
- All meters will be clearly labelled with serial number and end use
- Renewable energy generation will be sub-metered
- A thorough set of electrical schematics will be provided showing the locations of all meters and areas supplied, as well as information on maintenance and use of meters.

Main/sub metering is to be provided to comply with Building Regulations, Part L2, CIBSE guide TM39 and BREEAM requirements.

For the electricity metering the following principles should be followed:

- At least 90% of the estimated annual energy consumption for each fuel is to be metered separately.
- Any major plant that consumes more than 10% of the building energy should be sub metered.
- Sub metered per floor.
- Sub metering of lighting and small power separately.
- Sub metering any lettable spaces e.g. leased spaces to shops or businesses within UWE. Where meters are used for tenant billing purposes, these should be approved by the Measuring Instrument Directive (MID) or certified under UK national legislation as required.
  - Electrically powered space heating, cooling and DHW generating plant shall be individually and separately metered, not metered from combined HVAC plant panels that include other HVAC items such as pumps and AHUs.
  - Any cooling loads shall be metered separately.
  - Electricity meters shall have Modbus communications capability.
  - Schneider PM5111 or iEM3255 is the preferred electricity sub-meter.
  - Class 1 or better Current Transformers shall be used.
  - Where current transformers (CTs) are used they shall be appropriately sized to measure the electrical load and ensure they are not oversized.
  - CTs shall be installed and secured in accordance with manufacturer's instructions.
  - CT shorting terminal blocks shall be installed in an accessible location (e.g. metering compartment)
  - Fused disconnect protection shall be provided for each voltage reference and meter power supply.
  - All Modbus wiring in panels to be taken to a common accessible terminal within/near the panel.
  - Labels shall be installed adjacent to each meter describing the meter name in accordance with the university naming protocol.
  - All wiring shall be ferruled and clearly labelled/numbered.

Electricity sub-meters on the incomer to each panel board shall be multifunction to measure the following:

- Voltage (400/230V AC)
- kW & kVA
- Power Factor

- Line current on all phases and neutral
- kWh
- Maximum Demand
- Peak Amps/Volts
- Harmonic monitoring THD

Metering units shall be installed to all distribution boards either in the main switchboard or integrally in each distribution board.

All necessary equipment required to ensure that each metering unit can be connected onto the Estates Energy metering systems including data points and power supplies shall be provided. Where required, allowance shall be made for modifying and/or extending the existing system as required ensuring that it is sufficiently sized to accommodate the additional metering units within the buildings and an additional 25% spare capacity.

Where the system needs to be augmented then a complete system shall be installed.

Electricity meters shall be installed in accordance with the current version of BS 7671 (IET Wiring Regulations).

### 12.9.4 Metering software

Metering units shall be linked to the Estates Energy Metering system, communicating to the Tridium Niagara database. This includes electric, gas, water and heat meters. UWE's current metering contractor is Enica. On large projects, Enica must be engaged at the earliest opportunity (RIBA stage 2) to ensure joined up working. If Enica are not to be engaged directly by the project then a discussion with the UWE Carbon & Energy Team must take place to agree the types of meters to be installed and metering systems to be utilised.

Where communication is to be via a radio link, an analysis study shall be completed for the buildings to ensure that radio signals can reach the existing transmitter/receiver of the Estates Energy Monitoring Package and that there is spare capacity on the system. Where the signal strength is weak or not present then number of additional transmitter/receiver units shall be installed as required, at Project cost.

All meters must be fully installed, commissioned and operational at handover. The project should allow for the first tier of meters (building or block incoming meters) to be added to the eSight software platform for review by the Carbon & Energy Team prior to sign off.

### 12.9.5 Commissioning of Meters and Metering Systems

All meters (mechanical or electrical) must undergo individual commissioning processes to ensure correct installation, operation, and data accuracy. The meter commissioning process for each meter must include collection of the following as a minimum with evidence provided to UWE for each meter:

- Meter name.
- Meter location (including description).
- Photograph of as fitted meter and its location.
- Meter make, model (and serial if applicable).
- Copies of any meter calibration certificates etc.

- Meter communications type.
- Meter communications settings.
- Current transformer (CT) settings (including witnessing of actual CTs if feasible).
- Correct installation of each meter including correct CT installation.
- Description of which communications datalogger/system device it is connected to.